

Housing Bearing Support.

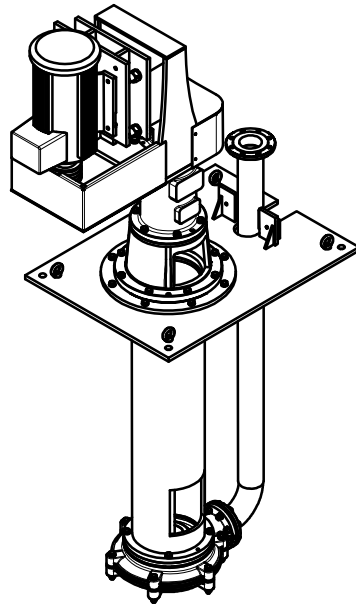

All Dimension in mm.

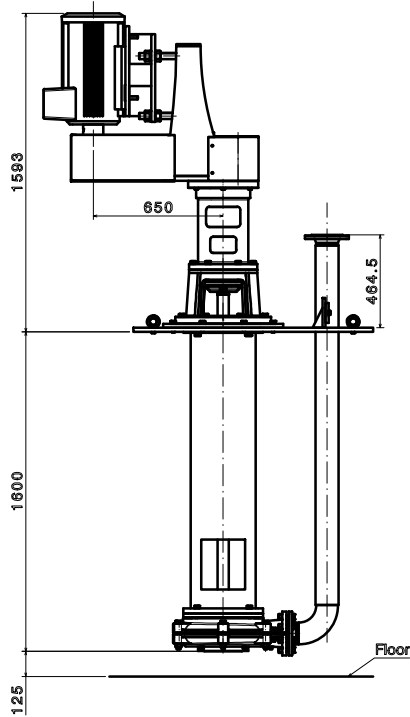
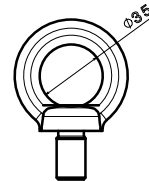

Lifting Eyebolt M16 Z=4

Pump Specification

Row	Item	Value
1	Flow Rate (m3/h)	-
2	Differential Head (m)	-
3	Motor Power (KW)	-
4	Pump Speed (RPM)	-
5	Motor Frame	160M
6	Shaft Sealing Plan	Soft Packing

Nozzle Specification

NO.	Connection	Size & Rating
1	Pump Suction	125 mm
2	Pump Discharge	EN1092-2/PN16/RF 10mm
-	-	-
-	-	-
-	-	-
-	-	-
-	-	-
-	-	-
-	-	-

Discharge Nozzle Loads

Forces (N)				Moments (N.m)			
Fx	Fy	Fz	Fres	Mx	My	Mz	Mres
-	-	-	-	-	-	-	-

Weight Data

Item	Weight (Kg)
Pump	450
Motor	-
Other	-
Total	-

Notes:
 All dimensions in mm.
 General Tolerances:
 Base plate overall length: +10mm
 Foundation bolt and spacing: +5mm
 Overall length pump set: +5mm

Customer: YAZD ROLLING MILL



General Arrangement Drawing

Designed by: T.Javani	Pump Model: VS4-SL-50-315-11-6-R1-160-0.6		
Drawn by:	DWG NO.:		
Checked by:	Project:		
Date:	Scale:	Size:	Revision: